



Experience the creative freedom to represent your brand and messaging at the entrance to your building. This matting system is your canvas with total colour control delivered by PMS colour printing technology to accurately reproduce your design on a high-quality and high-performance entrance matting system.

All entrance matting from Birrus can be customised to fit any shape and size. Our manufacturing standard lead time is up to 10 working days plus delivery time.



SYSTEM APPLICATIONS

Interior and Covered/Partially Covered Exterior.

Highly Recommended for:

- Commercial Buildings
- Office & Corporate Buildings
- Shops, Restaurants & Cafés
- Civic Buildings
- Hospitals & Healthcare Facilities
- Storage Facilities
- Sports & Big Event Venues
- Schools & Educational
- Factories

Recommended For:

- Car Parks
- Warehouses
- Apartment Buildings

Not Recommended For:

- Public Transport Facilities
- Residential Houses



ULTRAMAT Creative

Luxury - Quality - Reputation



TECHNICAL SPECIFICATION

GENERAL

- 10-Year warranty
- Slip tested to Australian standards
- Fire tested to Australian standards
- Adhesive free
- End-of-life return to manufacturer option

INSERTS

- Wider 75mm treads
- Creative freedom - accurately reproduce any colour, picture or logo
- Rebated inserts
- Insert replacement option
- Insert specification:
 - Description: 42-ounce woven Wilton
 - Colours: 295 standard PMS matching
 - Size: 200cm wide (off roll)
 - Weight: 1200gram
 - Pile fibre: 100% BCF nylon
 - Thickness: approx. 8mm
 - Primary backing: woven polypropylene
 - Critical heat flux: result = mean 4.3KW/M²
 - Mean smoke development: smoke value mean 171% (min)
 - Product features: high-density construction ensuring superior retention and abrasion resistance. Moth-proof, mildew-proof, non-allergenic.

EXTRUSIONS

- 6000-Series aluminium
- 50mm non-slip, furrowed treads
- Closed construction
- 10mm
- Finishing options:
 - Mill Finish
 - Clear/natural anodised (15-micron)
 - Antique bronze anodised (15-micron)
 - Midnight black anodised (15-micron)



INSERT COLOURS

Carpet Colours are Custom Created



LEARN
MORE



REQUEST
A QUOTE



REQUEST
A SAMPLE



ULTRAMAT Creative PROFILE DIAGRAM

10mm Closed Construction - Standard Installation

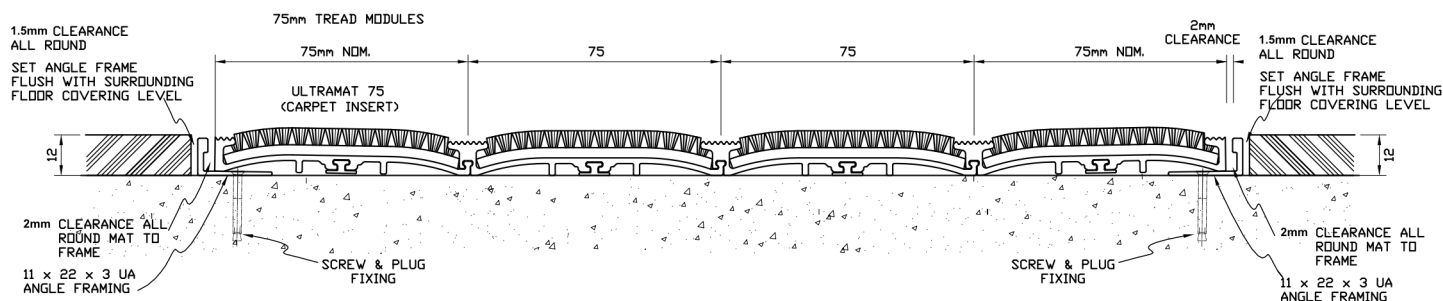

SYSTEM INSTALLATION

Birrus Installation Service is available – contact us for details.

Birrus Matting Systems require an internal recess depth of 12mm (10mm mat).

Standard Birrus matwell frames are fabricated using aluminium alloy, brass or stainless-steel angle for compatibility with our mats.

Place an angle in the recess and set angles level with adjoining floor surfaces. Glue in or screw fix as required. Contractors are advised to ensure proper performance of the entire assembly, it is absolutely necessary that the base of the matwell is formed to a level plane, using an engineered screed. We do not recommend sand and cement screed as it will break up over time.

A stepped profile (surface-mounted ramped), requires a minimum of 10mm clearance if a door is to pass over the mat.



CARE & MAINTENANCE

Vacuum clean matting regularly and, if required, spot clean carpet inserts with dry shampoo or steam clean as required.

Please contact us to purchase replacement inserts.

Restore lustre to ribbed aluminium sections by lightly rubbing over them with abrasive wool.